

New Designs 2016

DIBLEY 30 PERFORMANCE CRUISING YACHT

Inside this issue:

**New Designs 2016- 30-foot
Performance Cruising Yacht**
pg. 1, 2

**New Designs 2016- 30-foot
Corporate Race Yacht**
pg. 3, 4

Racing Results and News
pg. 5,6

From The Design Office -
pg. 6



Find us on Facebook:

Updated News, Results and Launchings that don't make the Newsletter, make our Facebook page. Come and visit.

Google Search
'Dibley Marine Facebook'

WE ARE ALSO ON THE WEB!
www.dibleymarine.com

DYD Ltd. SERVICES

- Naval Architecture
- Yacht Design
- Design Modifications
- Stability, STIX, AVS & Trim Analysis
- Keel and Rudder Design
- VPP & Performance Analysis
- Racing & Cruising Yachts
- Planing & Displacement Launches
- Design Reviews
- Project Management

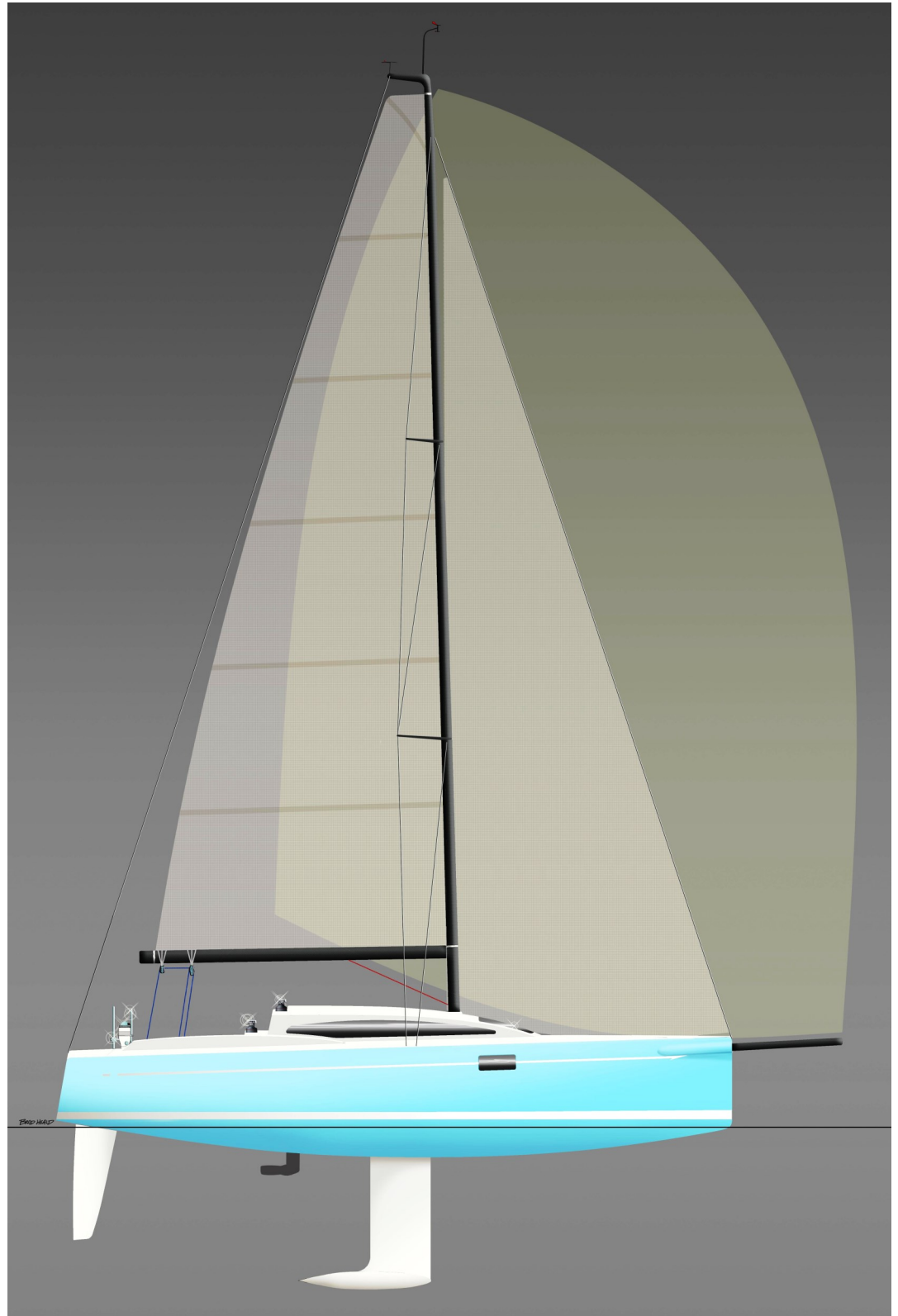

Recognised member



DYD Ltd. - New Zealand
P.O.Box 46-167 Herne Bay, Auckland, New Zealand
Email: info@dibleymarine.com
Web: www.dibleymarine.com

New Designs 2016 DIBLEY 30 PERFORMANCE CRUISING YACHT (cont)

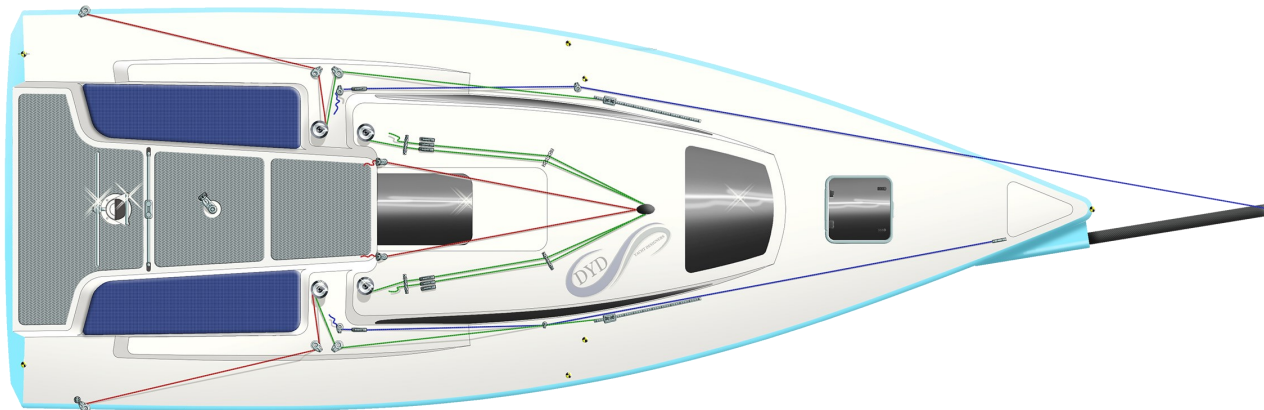

Earlier in the year we designed a 21-foot Sports yacht for the Chinese boatbuilding company 'Hangtong Yacht Manufacturing Co Ltd' which is currently getting ready for production.

Once that design was completed from our end, Hangtong approached us on another design request; a 30-foot performance cruising yacht that was fast, simple and easily crewed shorthanded. They had firm ideas on a few features such as the wheel steering but left us to come up with the best package for both sailing systems

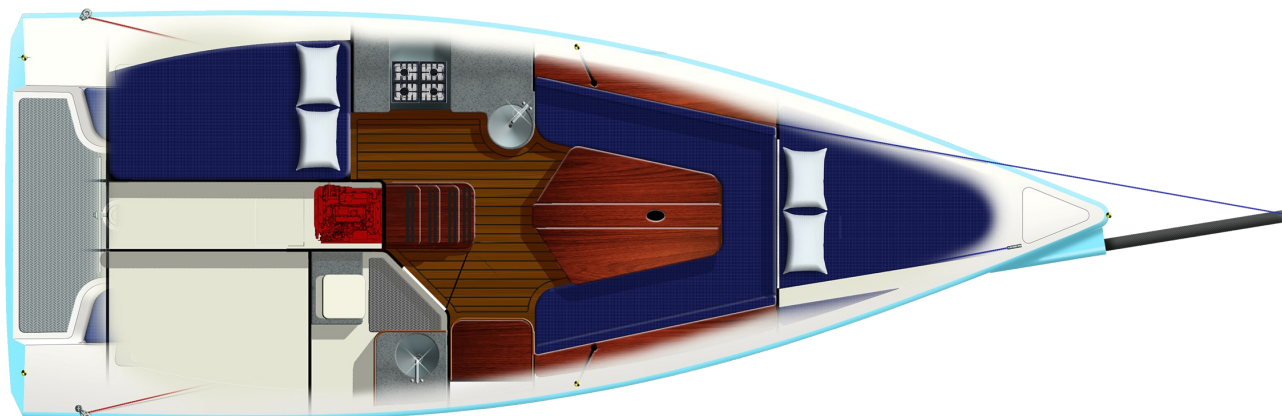

and interior comfort. The result is the Dibley 30 Cruiser featured here. An easily driven hull and a simple manageable sail plan are the key components to this design. The deck layout has all controls coming back to the cockpit and both tiller and wheel steering options are available. The prod pulls back into the yacht when not in use. Down below are two double berths and the saloon table which can drop to form further berths. A small navigation table, enclosed Head, and port Galley complete the layout. This open layout design allows for plenty of light coming in by way of the cabin windows and deck hatches.

LOA	9.140 m	(30' - 0")
LWL	8.600 m	(28' - 3")
BEAM	3.380 m	(11' - 0")
DRAFT	2.200 m	(7' - 3")
DISP (1/2 Load)	3,730 kg	(8,233 lbs')
SAIL AREA (Working)	51.361 sq.m	(552.85 sq.ft)

The Chinese sailing scene is growing rapidly and Hangtong see a market gap in this size and type of yacht. If the hull can be used to suit other types of yachting, then they are hoping to cover a large spectrum of the market.

More on next page.

Recognised member



DYD Ltd. - New Zealand
P.O.Box 46-167 Herne Bay, Auckland, New Zealand
Email: info@dibleymarine.com
Web: www.dibleymarine.com



New Designs 2016 DIBLEY 30 CORPORATE RACING YACHT



Recognised member



DYD Ltd. - New Zealand
P.O.Box 46-167 Herne Bay, Auckland, New Zealand
Email: info@dibleymarine.com
Web: www.dibleymarine.com

New Designs 2016 DIBLEY 30 CORPORATE RACING YACHT (cont..)

Once the preliminary design process began for the Dibley 30 Cruising Yacht shown on previous pages, we were asked whether it was feasible to use different deck moulds to produce a corporate race yacht with the same hull. As a result we reconfigured a few of the design features and came up with two versions of the 30 using the same hull and sail plan.

The Dibley 30R is designed for fun sailing in local club races and corporate regattas where people new to racing are able to get out and give it a go without having a yacht that can be a handful even with a fully experienced race crew. The deck layout is simple and easily controlled short handed. The swept spreader rig and protruding prod support a powerful sail plan that will allow this yacht to show its full potential. For those looking for a more turbo version, a larger square-top main can be designed with runners, though initial focus will be for the tamer version.

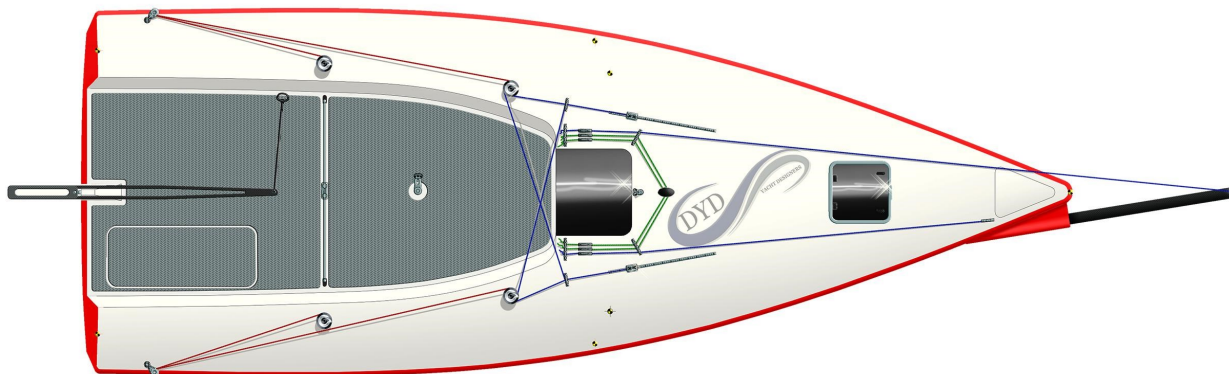

Shown is a transom hung rudder on Hangtong's request, but a tiller steered rudder under the yacht as per the Dibley 30C can easily be utilised. The hull form is stable and slippery with a chine aft that disappears going forward. Down below there is seating and open berths but the areas main use is for sail storage.

We will update progress in the next newsletter on the more powerful appendage package and larger sail plan.

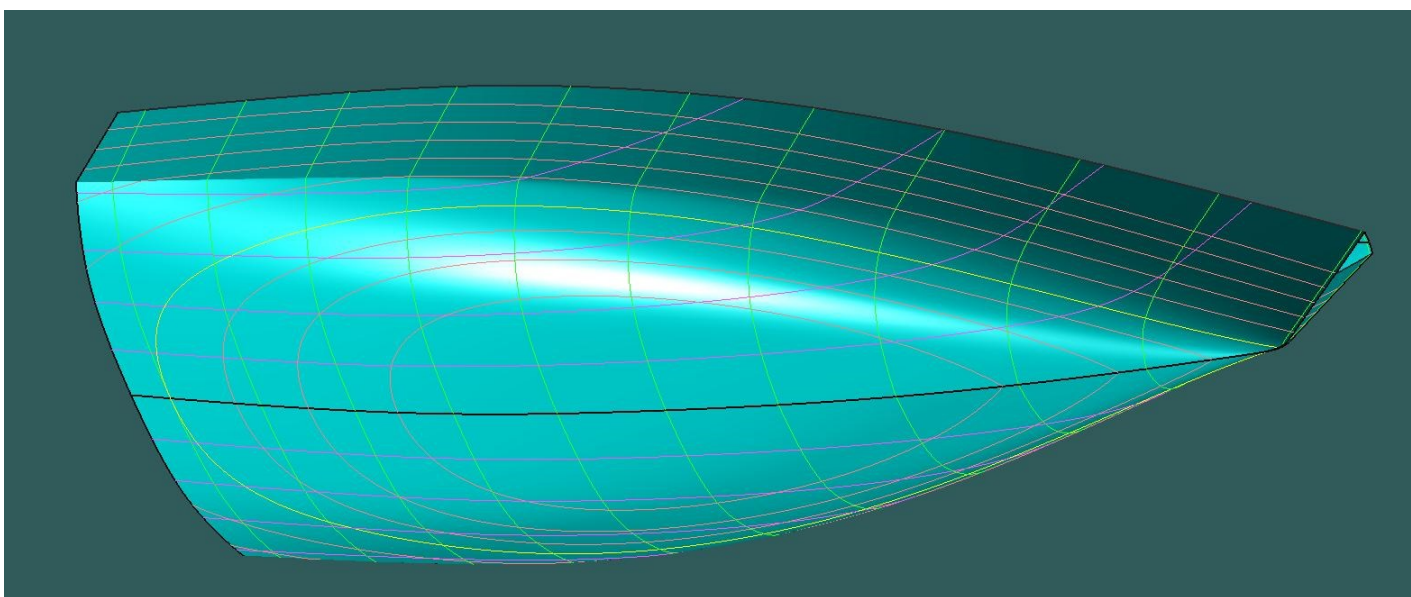

Recognised member



DYD Ltd. - New Zealand
P.O.Box 46-167 Herne Bay, Auckland, New Zealand
Email: info@dibleymarine.com
Web: www.dibleymarine.com

RACE RESULTS AND NEWS



2016 China Coast Regatta Cup; 22-24 October 2016.

2016 China Cup; 27-30 October 2016

Ernesto Echauz, Stephen Tan and crew have had a stellar year onboard 'Standard Insurance Centennial III'. With the start of her 2016/2017 Race season starting in October, she continued her form and took out 2nd Overall on IRC in this years China Coast Regatta, followed by 2nd Overall in IRC Division A in this years China Cup. Tied for first with 'Hero Racing' skippered by Tiffany Koo, the count back allowed 'Hero Racing' to edge into 1st due to her three 1st place finishes in 6 races, as opposed to Ernesto's two 1st place finishes.

Standard Insurance Centennial III is a Davidson 52 we worked on with Laurie from the original concept through to launching for a USA owner back in the early 2000's. When Ernesto purchased

the yacht a few years ago, the Dibley Design Team designed new appendages, giving her a new lease of life on the race track. Updated rigging by Southern Spars and new sails by North completed the package. Well done team.

2016 Land Rover Sydney to Gold Coast Yacht Race; 3 October 2016.

Congratulations to John Cameron and crew who took out 2nd in PHS in this years 384 nautical mile Sydney to Gold Coast Race in his Dibley 46 'More Witchcraft'. Racing in fairly light conditions, John led the PHS fleet going into Day 2 but was just pipped at the post by the 47-foot Tripp design 'Abracadabra'. Line honours went to the R/P 100 'Wild Oats XI'.

John's next race is the 2017 Club Marine Pittwater to Southport Race starting on January 2nd. This 370 nautical mile race up the NSW East Coast is known as the 'Warm Water Classic' as opposed to the southern bound Sydney to Hobart which starts a week earlier.

We designed "More Witchcraft" back in 1995 and she launched in NZ in 1996 when she was known as 'Macs Out'. Beautifully built by Ian Vickers and his team, she eventually sold to Australia. John Cameron bought her in 2005. We updated her appendages before he entered the Sydney Hobart where he got a podium finish in his division.



Dibley 8-m updates: New Zealand and Ireland:



Supergroove—Ireland

Springloaded – NZ



Supergroove and *Springloaded* have both had design updates over the last few months and the performance increase has given these older Dibley designs a new performance edge.

Both yachts sport new square-top mains and sail wardrobes by Zoom Sails in Christchurch, NZ. The results are more speed and better height with extra power available when needed.

Springloaded added a new 2016 Dibley designed bulb and keel built by Davie Norris Boatbuilders in Christchurch. Bulb pour by Mike Rees and Engineering by Peter Lawson.

More updates on our Facebook page.

Recognised member



DYD Ltd. - New Zealand
P.O.Box 46-167 Herne Bay, Auckland, New Zealand
Email: info@dibleymarine.com

Web: www.dibleymarine.com

WE ARE ON THE WEB!
www.dibleymarine.com

Sailing Links and News

Westlawn Institute of Marine Technology
www.westlawn.edu

Sailing Anarchy
www.sailinganarchy.com

New Zealand Marine
www.nzmarine.com

Asian Yachting
www.asianyachting.com

History of IOR Blog
www.rbsailing.blogspot.co.nz/

Shorthanded Sailing Association of NZ
www.ssanz.co.nz

Royal New Zealand Yacht Squadron
www.mzys.org.nz

Kraken Yachts
www.krakenyachts.com

From the Design Office:

We are ending the 2016 year as busy as ever with plenty of work coming in and some great success both in design results and happy clients.

This year saw a new 21-footer, two 30-footers, and a 50-footer come off the design board and between these, were multiple appendages, rig, deck and interior redesigns for existing yachts and launches. The yacht design game is as wide as it is varied and the pleasure of working with some great owners, fellow designers and others in the industry make each day very rewarding.

For us down south, summer is here and boating takes priority over most things. Up north winter is allowing owners to upgrade existing yachts and or dream of new designs for the New Year.

Wishing you many safe excursions over the Christmas Season. We look forward to hearing from you in the New Year.

Neil Spencer (NZ, Australia)
 Kevin Dibley (Queenstown, NZ)



2016 Racing Results and News (continued)

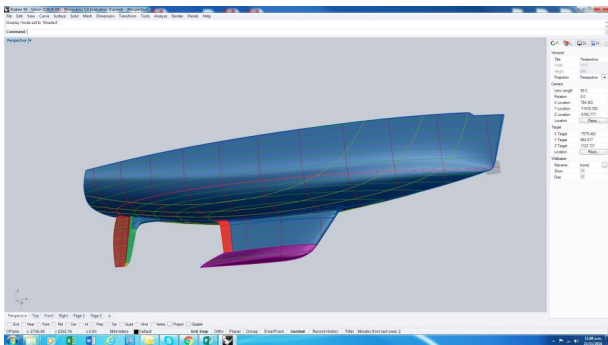

Kraken 50 Update: November 2016. China;

Progress is well underway with the Kraken 50 Bluewater Cruising Yacht featured in earlier newsletters. Our structural engineer Peter Lawson, is detailing the construction drawings. Our 3D modelling expert, Simon Paul, is finalising the 3D Hull model for plug and mould construction in China.

Hansheng Yachts, based in Xiamen City China, are lined up to begin the plug and moulds so that full production can begin in 2017. Kraken Yachts have sold the first 50 to a British businessman with thousands of

miles of Bluewater sailing under his belt. Looking for comfort, seakindliness and safety, he found all his requirements in the K50.

Kraken Yachts recently launched their flagship 66-foot 'White Dragon' in Taiwan and CEO Dick Beaumont and Managing Director Roger Goldsmith delivered the yacht to Hong Kong mid November. Some very good drone footage of the delivery can be seen on their updated website www.krakenyachts.com.

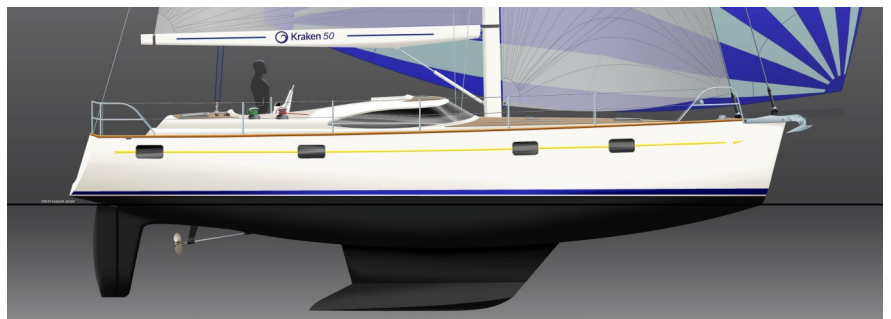

'White Dragon' will be Dick Beaumont's own family yacht and he has plans to set sail into the Pacific and beyond over the next few years while the rest of the Kraken fleet grows. Following the Kraken 50 will be their mid sized Kraken 58 which has the same design features as the K50 but with more internal volume and cabins. More updates in next Newsletter.

Recognised member



DYD Ltd. - New Zealand
 P.O.Box 46-167 Herne Bay, Auckland, New Zealand
 Email: info@dibleymarine.com
 Web: www.dibleymarine.com